

GRID LOCATION  
1-3/C

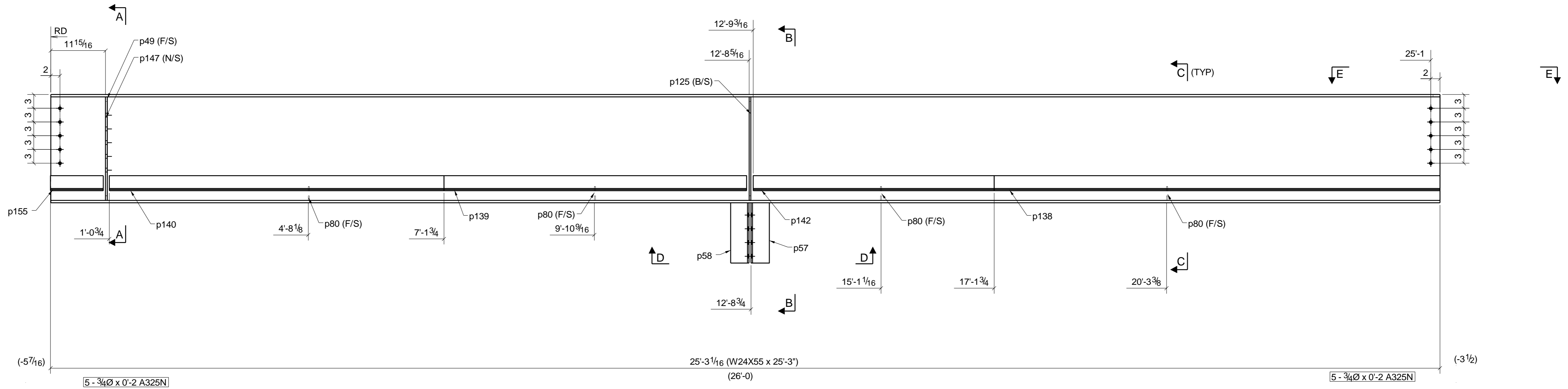
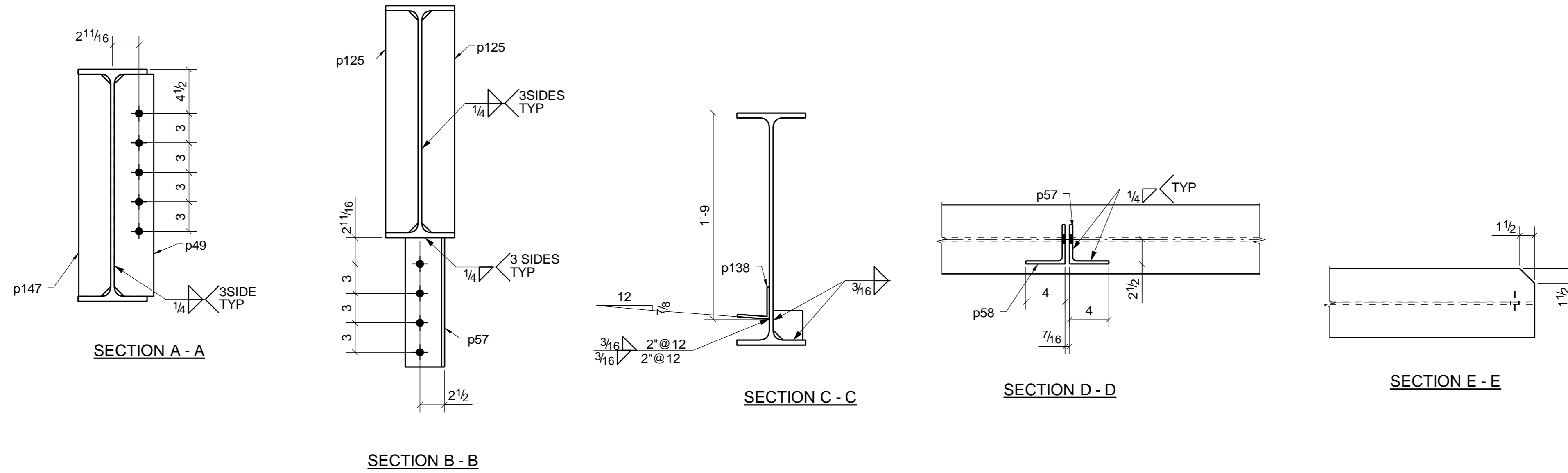

SHOP NOTES:-  
1.NO PAINT 3 AROUND HOLES  
2.NO PAINT AT UNCAPE & CHANNEL & HSS  
3.NO PAINT AT END OF MOMENT PREP.  
4.N.P INDICATE NO PAINT AREA.  
5.HATCH INDICATE NO PAINT AREA.

**BILL OF MATERIAL**

SHIP MARK	PIECE MARK	QTY	DESCRIPTION	LENGTH	REMARKS
B36		1	BEAM		
	B36	1	W24X55	25'-3"	
	p49	1	PL3/8"X4"	1'-10 5/8"	
	p57	1	L4X4X5/16	1'-1 3/16"	
	p58	1	L4X4X5/16	1'-1 3/16"	
	p80	4	PL1/4"X3"	0'-3"	
	p125	2	PL3/8"X3 5/16"	1'-10 5/8"	
	p138	1	PL1/4"X6"	8'-1 1/4"	(BENT)
	p139	1	PL1/4"X6"	5'-6"	(BENT)
	p140	1	PL1/4"X6"	6'-1"	(BENT)
	p142	1	PL1/4"X6"	4'-4 9/16"	(BENT)
	p147	1	PL3/8"X3 1/4"	1'-10 5/8"	
	p155	1	PL1/4"X6"	0'-11 1/2"	(BENT)

**FIELD BOLTS**

QTY	DESCRIPTION	LENGTH	REMARKS
10	3/4" Ø A325N BOLTS	0'-2"	w/NUT & WASHER

**SHOP NOTES**

REF. DRAWINGS: E2	All Pipe: A53 GR-B	U.N.O.
All Material: A36	All Rebar: A706	U.N.O.
All W-Flange: A992	All Headed Studs: A108	U.N.O.
All TS: A500 GR-B	Welds: E70XX	U.N.O.

BLUE PRINTS			BLUE PRINTS			BLUE PRINTS		
NO.	DATE	FOR	NO.	DATE	FOR	NO.	DATE	FOR

**APPROVAL/REVIEW AUTHORITY:**  
PLEASE REVIEW THIS DRAWING CAREFULLY IT REPRESENT OUR INTERPRETATION OF THE INTENT OF THE CONTRACT DOCUMENTS, HOWEVER, THE STEEL FABRICATOR AND THE STRUCTURAL DETAILER ASSUMES NO RESPONSIBILITY FOR THE ACCURACY OF THE INFORMATION SHOWN ON THIS DRAWING. THIS IS THE RESPONSIBILITY OF THE BUYER.  
UNLESS NOTED TO THE CONTRARY ON THIS DRAWING WHEN IT IS RETURNED FROM APPROVAL, IT WILL BE ASSUMED THAT ALL INFORMATION SHOWN HEREIN HAS THE AFFIRMATION OF APPROVAL AUTHORITY.  
SUBSEQUENT CHANGED INFORMATION SHOWN ON THESE DRAWINGS AFTER FIRST SUBMISSION WILL BE CONSIDERED AS CONTRACT CHANGES.  
ADOPTED BY THE AMERICAN INSTITUTE OF STEEL CONSTRUCTION.

**FOR FABRICATION**

NO.	DESCRIPTION	DATE
1	For Fabrication	

ITEM	BEAM	DRAWN BY: JKV	
JOB	NORMS RESTAURANTS, LLC	DATE	
LOCATION	17904 LAKEWOOD BLVD BELLFLOWER, CA	CHECKD BY: JKS	
ARCH.	GEOFFREY B.LIM	DATE 06/16/17	
CONTR.	----	APPROVED	
ENGR.	McVEIGH & MANGUM		
JOB NO.	HOLE SIZE U.N.	FINISH	DRWG. NO.
--	13/16	1 S/C PRIM	B36

ONE ~ BEAM ~ B36