

DETAIL-E (2 LOC.)
 (2 @ ABP1) (REF: 1/SD1)
 (REF: A/SD4)

4-1 ϕ x2'-3 ASTM F1554. GR55
 THREADED ROD ANCHOR BOLTS
 w/ 4 NUT & PLATE WASHER PER MK:-AB3.
 TEMPLATE 12GAx16x2'-0 MK:-TP5

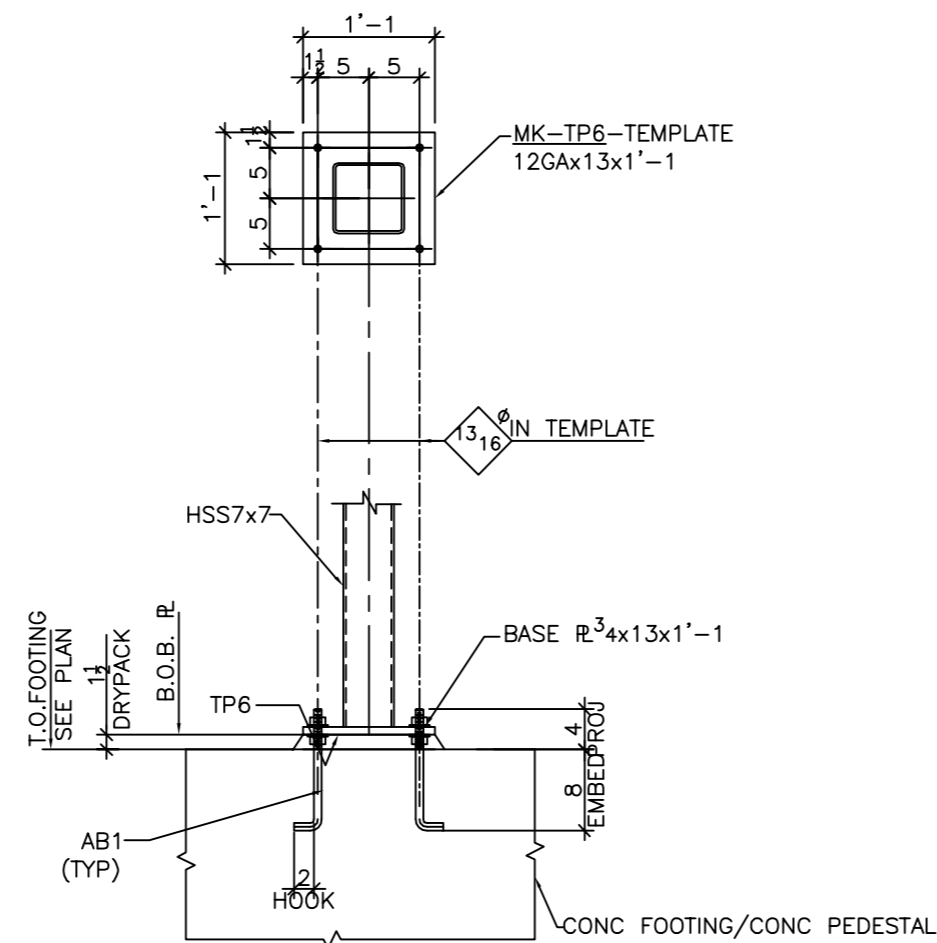

DETAIL-F (3 LOC.)
 (3 @ ABP1) (REF: 9,10/SD1)

4-3/4 ϕ x 1'-0 ASTM F1554. GR55
 J ANCHOR BOLTS
 w/ 2 NUT & STD WASHER PER MK:-AB1.
 TEMPLATE 12GAx13x1'-1 MK:-TP6

| FOR FIELD USE | | | |
|---------------|---------------------------|-----------------|-----------|
| NO. | DESCRIPTION | DATE | |
| | ISSUED FOR FIELD USE | 08/07/17 | |
| | ISSUED FOR APPROVAL | 06/20/17 | |
| ITEM | ANCHOR BOLT DETAILS | DRAWN BY: MAE | |
| JOB | H&M | DATE: 06/16/17 | |
| LOCATION | US183 VICTORIA GARDEN T.I | CHECKED BY: FIM | |
| ARCH. | LDA DESIGN GROUP INC, | DATE: 06/16/17 | |
| CONTR. | . | APPROVED | |
| ENGR. | HSA & ASSOCIATES INC, | | |
| JOB NO. | HOLE SIZE U.N. | FINISH | DRWG. NO. |
| . | 13/16 ϕ | -- | ABP3 1 |

| BLUE PRINTS | | | BLUE PRINTS | | | BLUE PRINTS | | |
|-------------|------|-----|-------------|------|-----|-------------|------|-----|
| NO. | DATE | FOR | NO. | DATE | FOR | NO. | DATE | FOR |
| | | | | | | | | |
| | | | | | | | | |
| | | | | | | | | |

APPROVAL/REVIEW AUTHORITY:
 PLEASE REVIEW THIS DRAWING CAREFULLY IT REPRESENT OUR INTERPRETATION OF THE INTENT OF THE CONTRACT DOCUMENTS, HOWEVER, THE STEEL FABRICATOR AND THE STRUCTURAL DETAILER ASSUMES NO RESPONSIBILITY FOR THE ACCURACY OF THE INFORMATION SHOWN ON THIS DRAWING. THIS IS THE RESPONSIBILITY OF THE BUYER.
 UNLESS NOTED TO THE CONTRARY ON THIS DRAWING WHEN IT IS RETURNED FROM APPROVAL, IT WILL BE ASSUMED THAT ALL INFORMATION SHOWN HEREIN HAS THE AFFIRMATION OF APPROVAL AUTHORITY.
 SUBSEQUENT CHANGED INFORMATION SHOWN ON THESE DRAWINGS AFTER FIRST SUBMISSION WILL BE CONSIDERED AS CONTRACT CHANGES.
 ADOPTED BY THE AMERICAN INSTITUTE OF STEEL CONSTRUCTION.